

MERROW®

SEWING MACHINE COMPANY



LEARN MORE
ABOUT THE MG-2DFS-2

- ATHLETIC GARMENTS
- ACTIVE WEAR
- SPORTS APPAREL
- TECHNICAL BASE LAYERS

Internal Cams maintain critical tolerances between needle, needle plate and looper to ensure consistent and uniform stitch coverage

Integrated Parts are designed for adjustment to allow sewing of different fabric types and weights

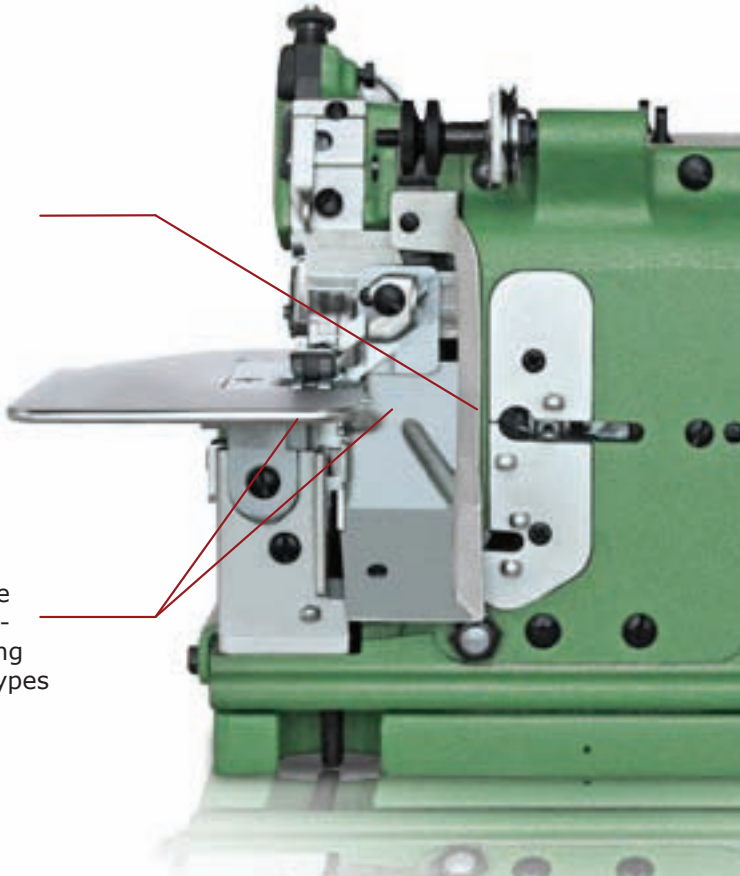

MERROW MG-2DFS-2 SPECIFICATIONS

OPERATING SPEED:	5500 Rpm
STANDARD STITCH ECCENTRIC :	28 spi
STITCH ECCENTRIC RANGE :	20-40 spi
STANDARD NEEDLE :	2DF
NEEDLE RANGE:	0SD-5DF
STITCH TYPE	617
STITCH WIDTH :	5/32" (3.9mm)
NUMBER OF THREADS	2



Front (On Rambouillet Wool)



Back (On Rambouillet Wool)

MG-2DFS-2

INDUSTRIAL FLAT SEAM SEWING MACHINE

FEATURES

- COMPACT FOOTPRINT
- **MODERN REPLACEMENT FOR THE FLAT LOCK STITCH**
- DESIGNED TO SEW ON TODAY'S TECHNICAL BASE LAYERS
- Made in the USA
- 10 Year Warranty



WWW.MERROW.COM/MG2DFS2

MERROW